

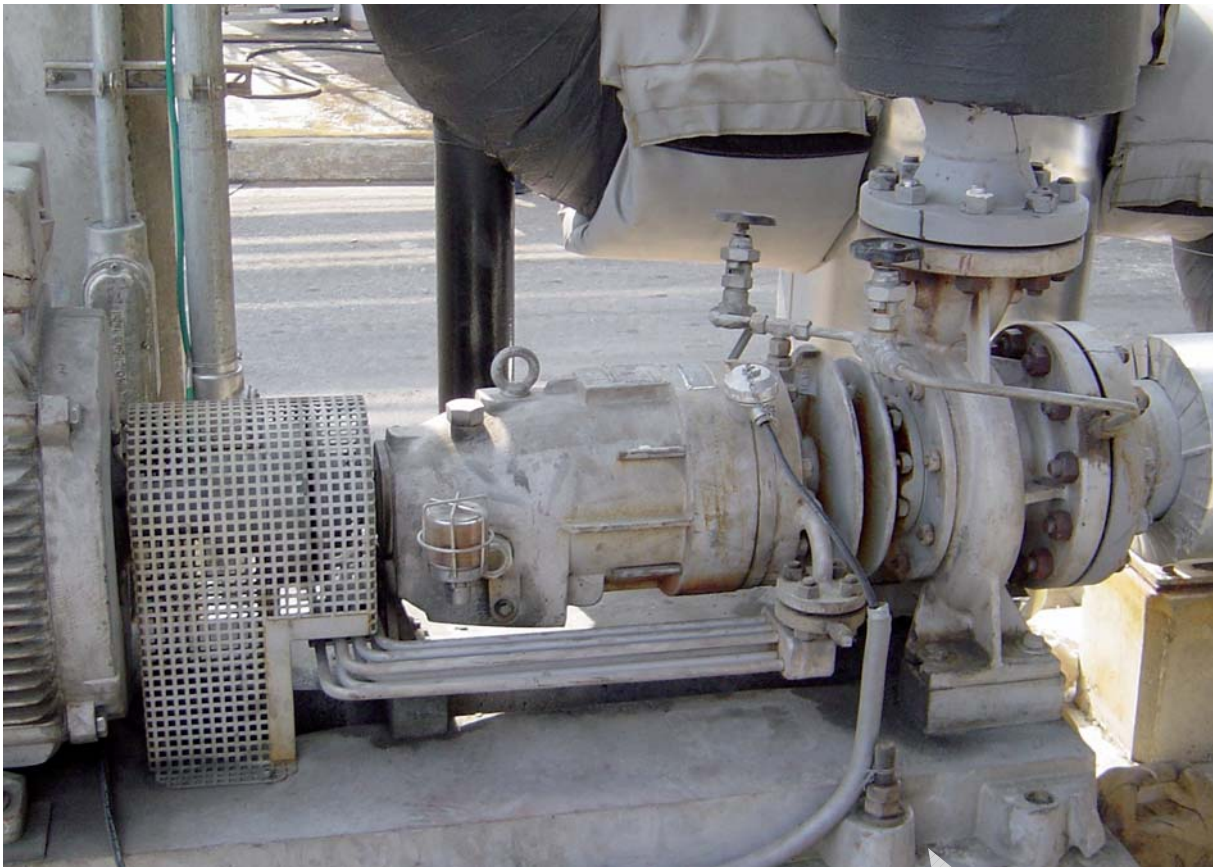

**DICKOW
PUMPEN**

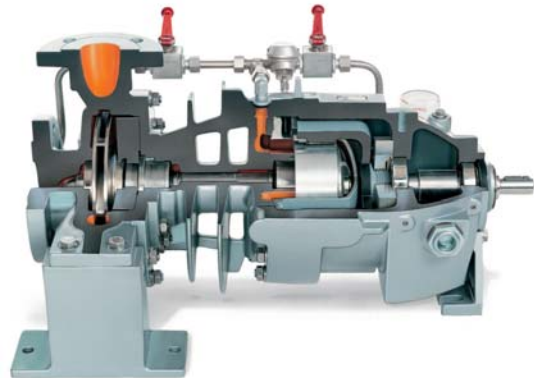

**Sealless Magnetic Coupled
Hot Oil Circulation Pumps
acc. to DIN EN 22858 / ISO 2858**

Type NMWR / NMWB / NMW

*our
contribution
for
environmental
protection*

General

DICKOW pumps of series NMWR / NMWB / NMW are sealless centrifugal pumps with magnet coupling. The static containment shell forms a closed system with hermetically sealed liquid end.

Applications

The leakage free pumps are designed for handling thermal oil with a temperature range from 250 to 400 °C (482 to 752 °F) without water cooling. The containment shell replaces double acting mechanical seals with external fluid reservoirs and the necessary control equipment.

Max. capacity and differential head:
50 Hz - appr. 900 m³/h and appr. 150 m
60 Hz - appr. 1000 m³/h and appr. 220 m
(appr. 4400 gpm and 720 ft)

Design / Pump casing

NMWR / NMWB / NMW-pumps are single stage volute casing pumps with closed impellers, back-pull-out design, with end suction and top discharge flange. Sturdy feet are provided as standard for mounting on the base plate. Centerline mounted design is available on request.

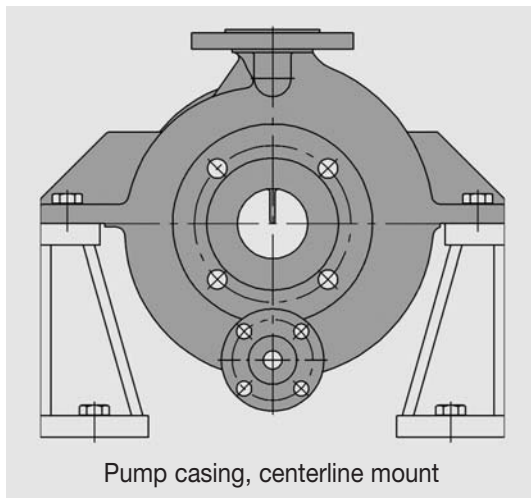

Pump casing, centerline mount

Capacity and outer casing dimensions comply with DIN EN 22858 resp. ISO 2858.

Containment shell

The containment shell is a pressure vessel to separate the pumped liquid from the atmosphere only. The shell is not used as an additional bearing holder. Therefore, no dynamic stress occurs.

The standard containment shell is a one piece deep-draw design without additional welds made of 2.4610 (Hastelloy C).



Other available material options are:

- Zirconium oxide (industrial ceramic) without eddy current losses.
- Titanium for high pressure applications.

The containment shell is bolted to the bearing housing in a manner that allows removal of the bearing bracket together with the drive rotor without draining the pump.

Magnet coupling

The single elements of the multipolar magnet coupling are manufactured of permanent magnet material "Cobalt Samarium" with unlimited lifetime. The magnets in the driven rotor are completely encapsulated, not in contact with liquid. Power is transmitted to the hermetically sealed liquid end by a bank of external magnets. Inner and outer magnet rings are locked together by magnet forces and work as a synchronous coupling. The inner magnet ring transmits the required torque direct to the impeller. Overload of the magnet coupling and slipping will not cause demagnetization if temperature monitoring is available. The magnet couplings are designed for electric motors, direct on line starting.

Should a increase of motor power be required, i.e. when installing a larger impeller, the nominal power of coupling can be increased with additional magnets.

The maximum drive power is approx.
170 kW @ 50 Hz (203 kW resp. 270 hp @ 60 Hz).

Bearing housing with cooling fins

The transmissible power of the Cobalt Samarium coupling depends on the operating temperature of the magnets which should not exceed 250 °C (482 °F). For applying the pumps also with temperatures between 250 and 400 °C (482 and 752 °F), the bearing housing is designed as a cooling device with cast-on fins. The heat dissipation to the atmospheres keeps the temperature in the containment shell well below the system temperature in the volute casing. The magnet temperature depends on the magnet losses. The containment shell temperature with a loss of 1,1 kW is appr. 160 °C (320 °F) and increases with a loss of 1,9 kW to appr. 230 °C (446 °F).

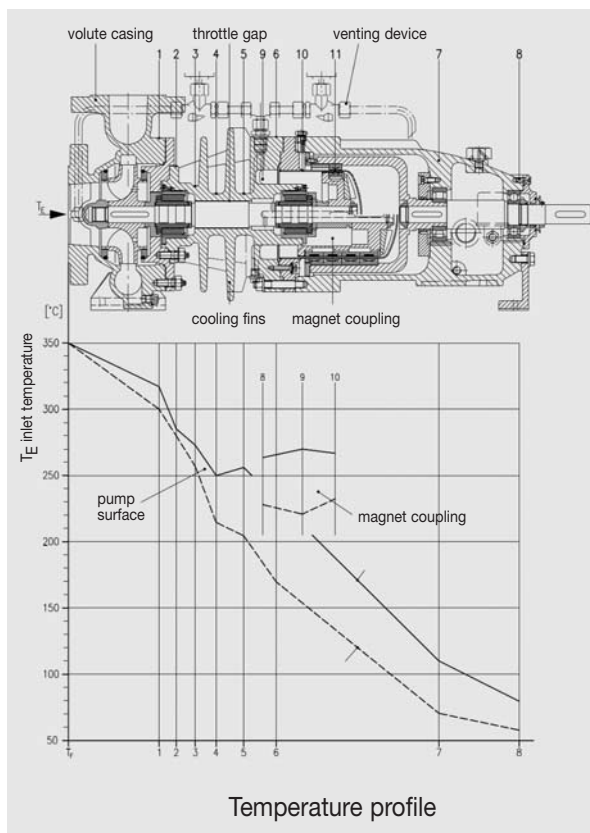

That means, the magnet losses of pumps with "dead end" design should not exceed 2,0 kW. Another advantage of this design is the separation of magnet chamber and volute casing. There is no internal circulation and the sleeve bearing on impeller side and the throttle gap prevents exchange of dirty product with clean liquid in the magnet area. Penetration of ferritic solids such as welding beads, pipe scale and rust sediments is therefore excluded.

External cooler

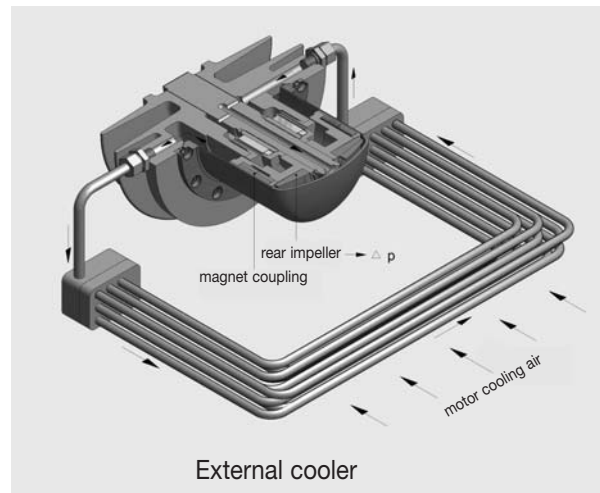

For drive powers higher than 22 kW and magnet losses above 2,0 kW, an additional external cooling loop is required.

The rear impeller on the rotor creates a circulation which cools down the heated liquid (by the containment shell) through the external cooler by dissipation to the atmosphere.

An additional cooling fan, mounted on the elastic coupling, can further improve the cooling effect.

Double sleeve bearings

The pump shaft is carried in wetted sleeve bearings. Standard material is pure Silicon Carbide with DLC coating, providing limited dry run capability. SiC is highly resistant to corrosion and wear and can be used for all kind of liquids, also for solid containing products. The SiC-components are elastically beared and therefore protected against shock and thermal stress. Both sleeve bearings are bolted in one common bearing housing to grant correct alignment.

Outer ball bearings / Containment shell protection

The drive shaft of the NMWR is carried in generously dimensioned oil lubricated antifriction bearings, rated for 25000 operating hours. The oil bath is protected against the atmosphere by a labyrinth seal. Oil level is controlled by a constant level oiler and an additional sight glass. The oil chamber is sealed against the magnet coupling also by a labyrinth seal.

The clearances between the outer magnet coupling and the bearing bracket respectively the containment shell are sized to exclude rubbing of the magnetic coupling on the containment shell, even when ball bearings fails.

NMWR-Design

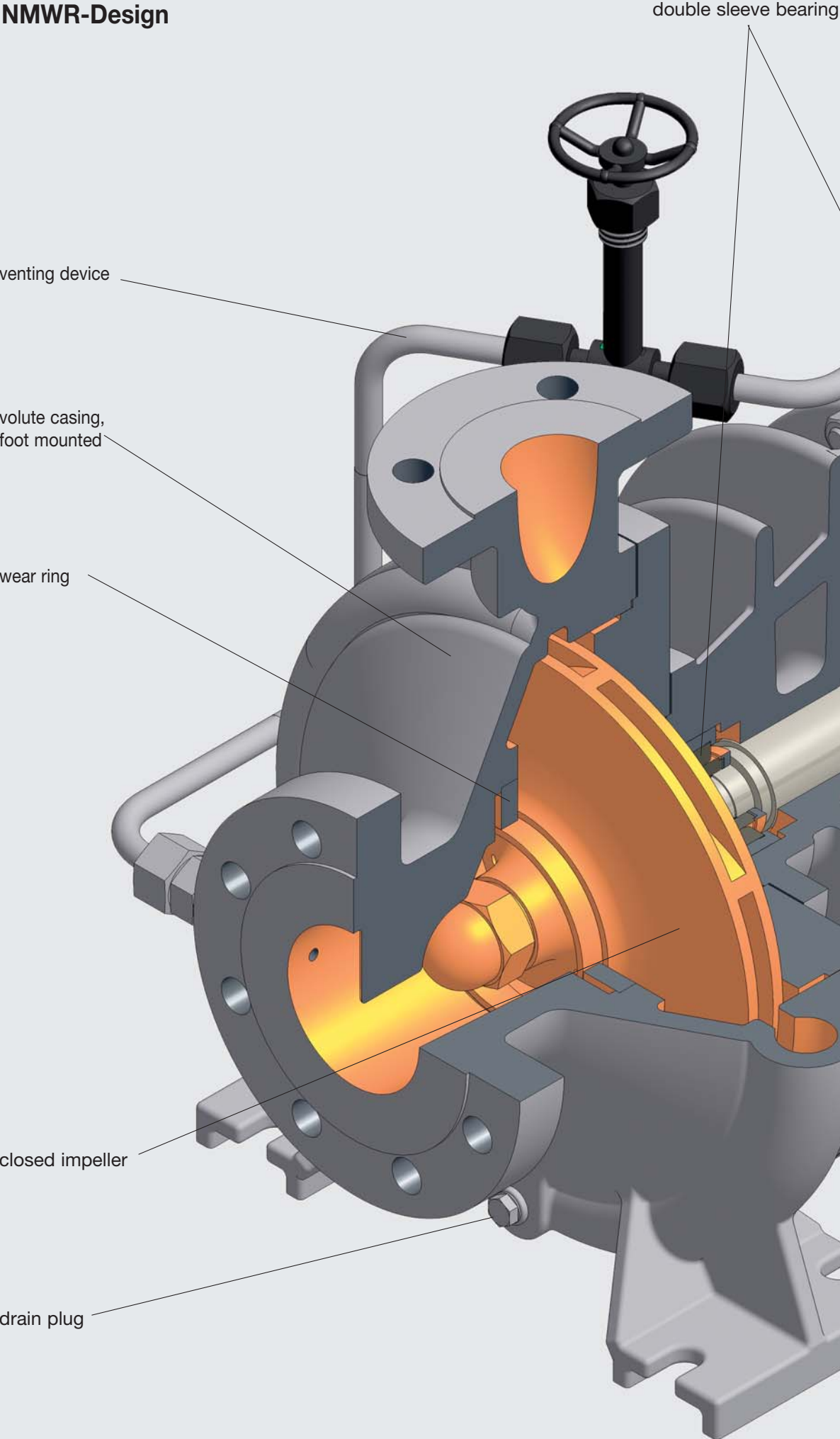

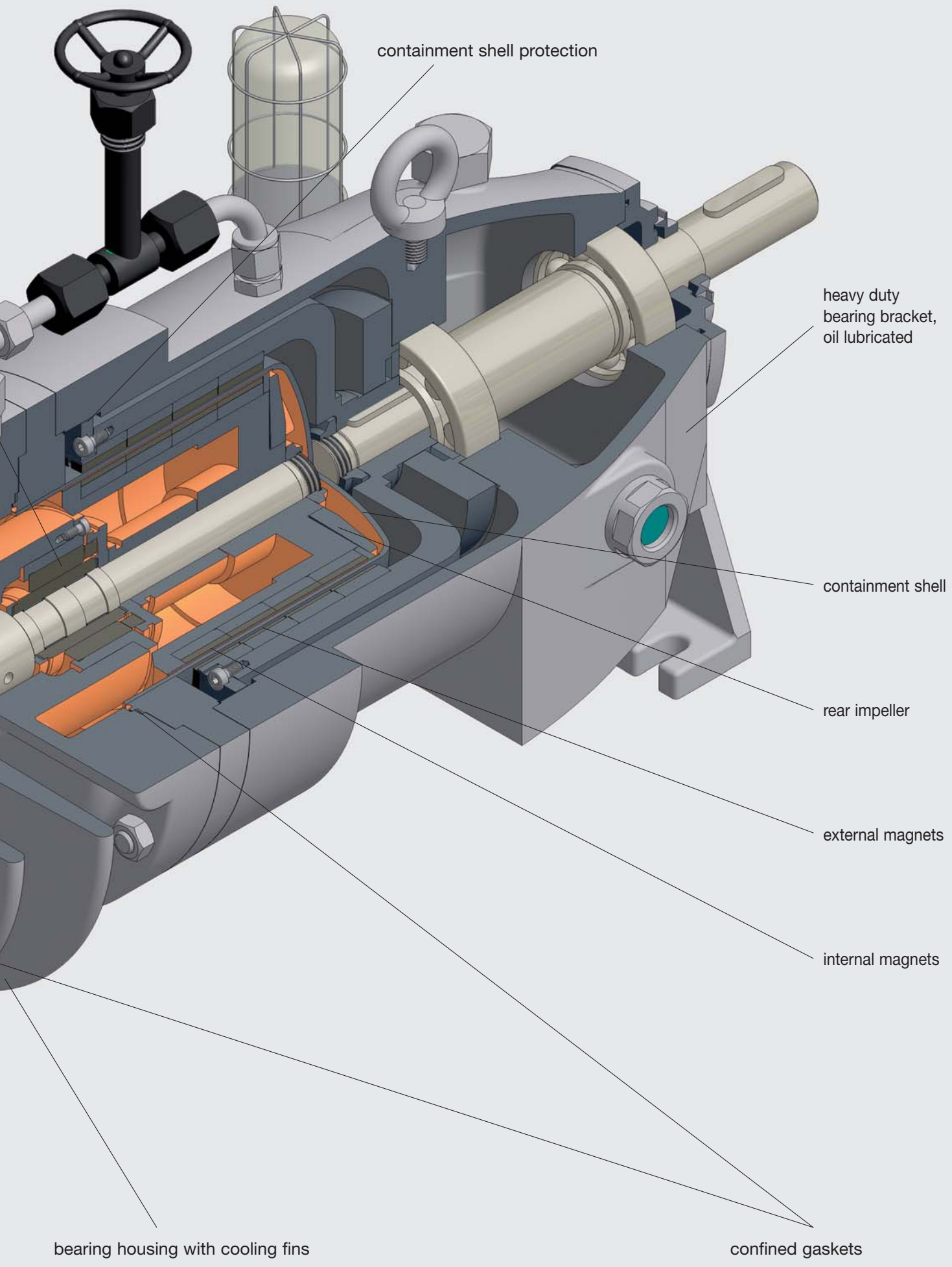

containment shell protection

heavy duty bearing bracket, oil lubricated

containment shell

rear impeller

external magnets

internal magnets

bearing housing with cooling fins

confined gaskets

NPSH-conditions / Inducer

The impellers are designed to achieve low NPSH-values over the complete operating range.

To improve NPSH-required conditions, additional inducers are available.

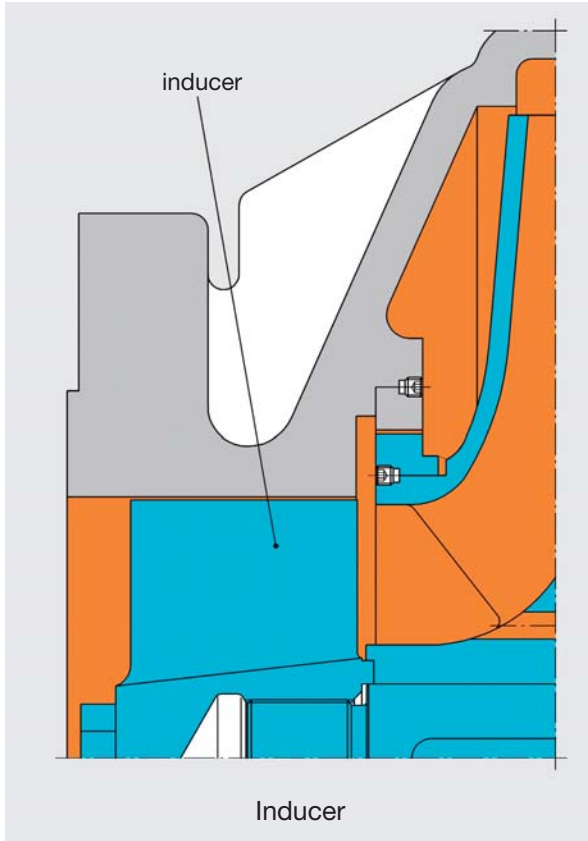

Retrofit of inducers on site is possible without change of suction pipe.

The inducers are designed in a way that NPSH-improvement is given from minimum flow up to maximum flow.

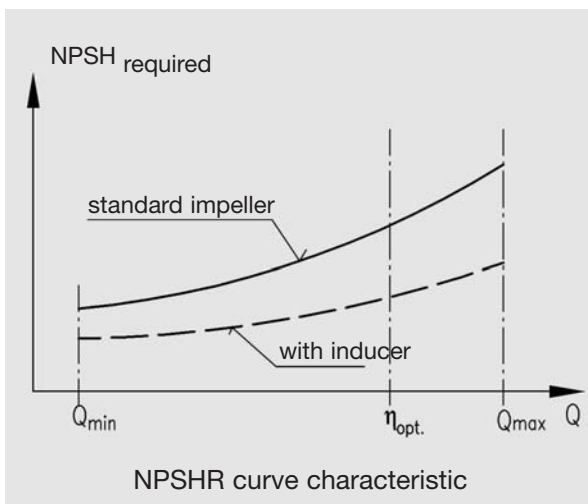

Draining

The magnet chamber and the volute casing are provided with separate drain connections.

Venting

NMWR / NMWB / NMW-pumps are not self-venting. They must be vented with open suction valve through the venting device under consideration of the operating instructions before start-up.

Balanced thrust loads

The thrust loads of the closed impellers are hydraulically balanced by wear rings, balance holes, back vanes and / or auxiliary impeller. The pump shaft connected to the impeller is floating.

Monitoring

Connections for PT100 temperature monitoring of the containment shell surface are available as standard.

Hazardous area

Together with the required Ex-drive motors, the pumps can be applied in hazardous area Group II, Category 2. The pumps meet the basic safety and health requirements of Explosion-proof Directive 94/9 EC and are suitable for plants with increased safety requirement.

Since the expected surface temperature is not depending on the ignition sources but on the temperature of the pumped liquid, no temperature class will appear on the pump. The temperature class will appear on the pump data sheet according to the liquid temperature. For example, a pump with an operating temperature of 360 °C (680 °F) will be certified with T1 (03 ATEX D092) and the user must ensure that no explosive atmosphere with an inflammation temperature of below 450 °C (842 °F) exists on site.

Optional designs

Type NMWB - close coupled design

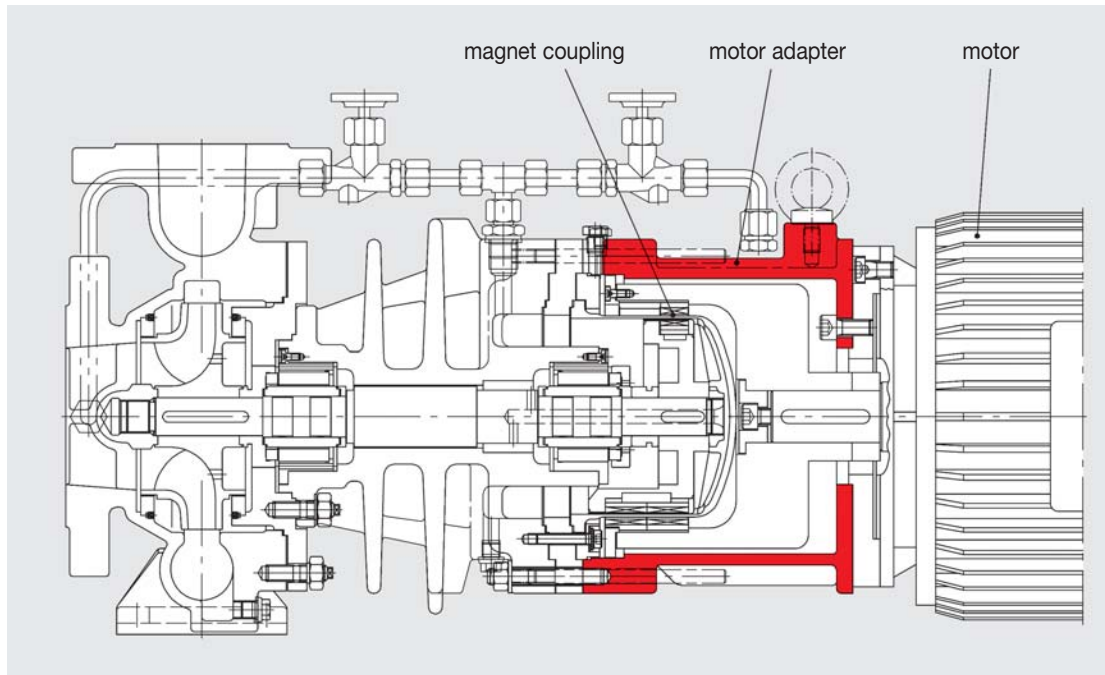

Type NMW - with grease lubricated ball bearings

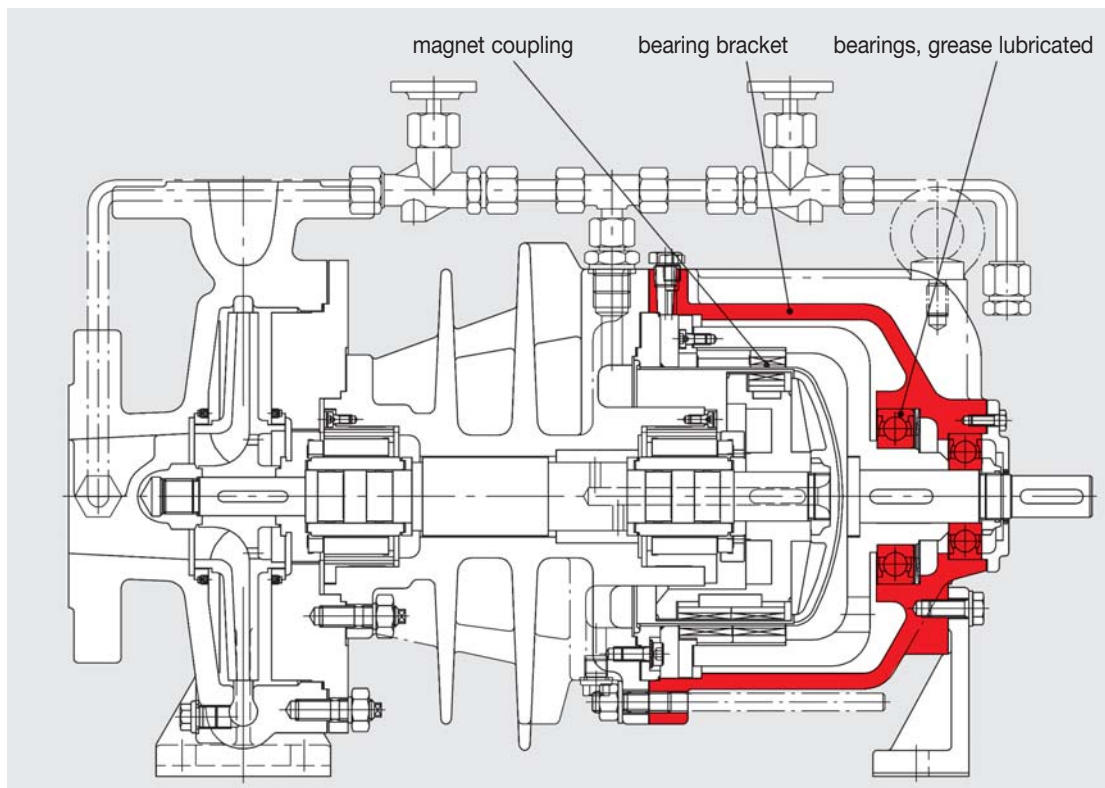

Performance range

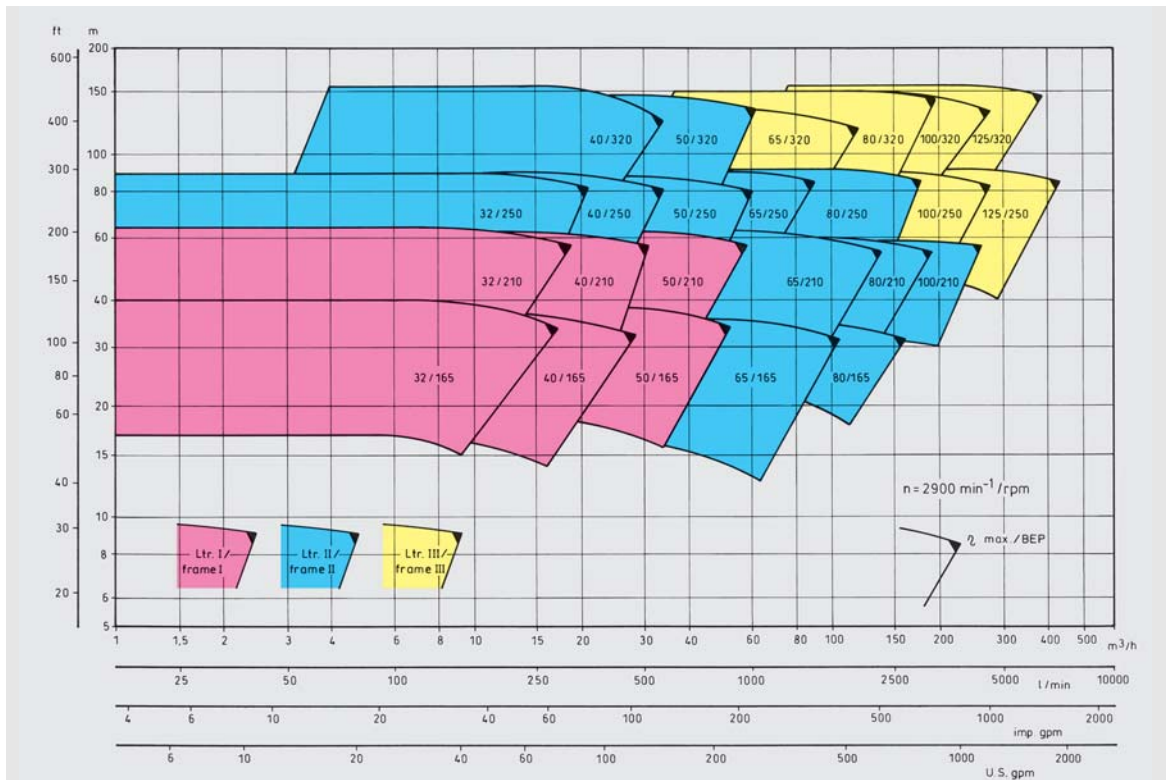
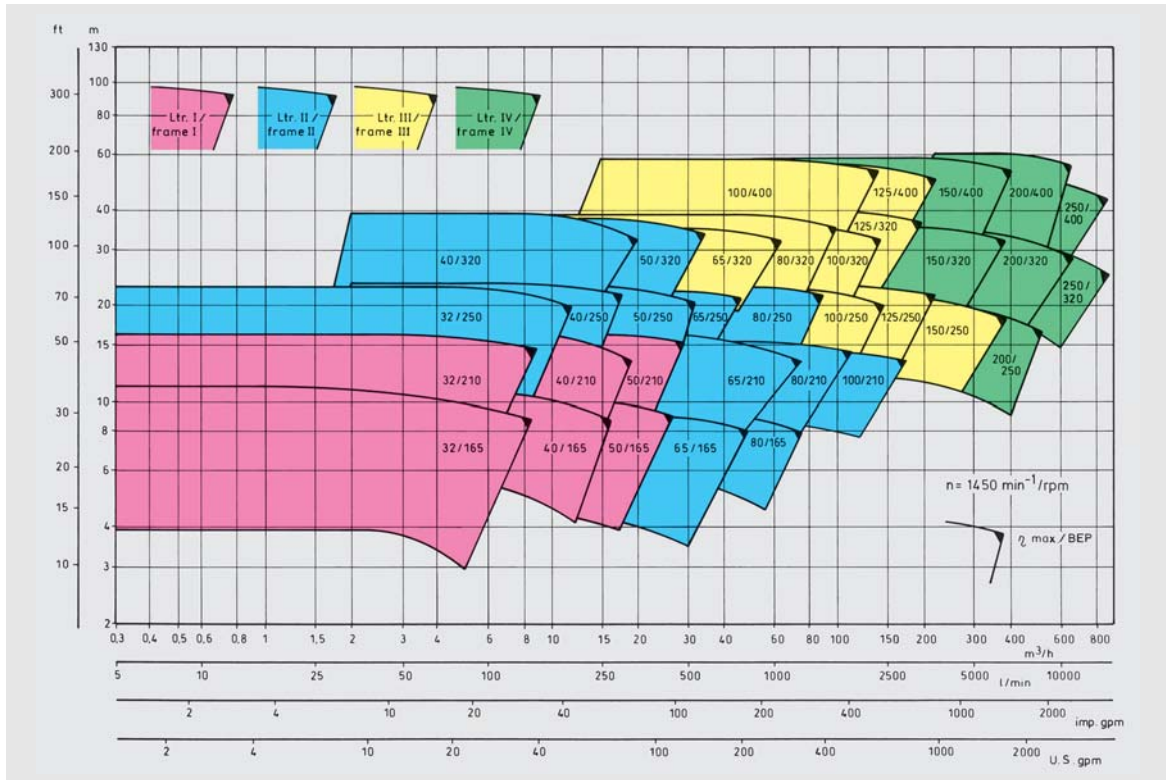

Performance curves of the individual pump sizes, also for 1750 / 3500 rpm, are available on request.