



**DICKOW  
PUMPEN**



Sealless Magnetic Coupled Gear Pump  
with  **Tuthill GlobalGear<sup>®</sup> Technology**

**Type GML / GMB**

## General

The GML/GMB gear pump combines the Dickow Pumpen magnet coupling design based on more than 30 years experience with Tuthill GlobalGear® built on a time-tested design and more than 80 years of gear pump engineering experience.

The result? An unbeatable pump that offers unparalleled performance and reliability.

## Applications

Magnetic driven GML/GMB-pumps are designed to improve plant and personnel safety, especially when handling toxic, explosive or other dangerous liquids which react on contact with the atmosphere. For all these services the containment shell replaces the single or double acting mechanical seals with external fluid reservoirs and the necessary control equipment.

GML/GMB-pumps therefore offer exceptional benefits to the chemical, petrochemical and allied industries, and protect the environment.

The pump handles everything from bulk transfer, chocolate and asphalt, to high-temperature fluids and chemical processing.

## Pump hydraulics

Robust pump design together with tough and strong materials make the pump last longer. The rotor and idler gears are made of tough materials, which can handle the stresses of high viscosity operation. No need for steel rotor upgrade. Revolutionary patented lubrication method extends overall life by reducing friction.

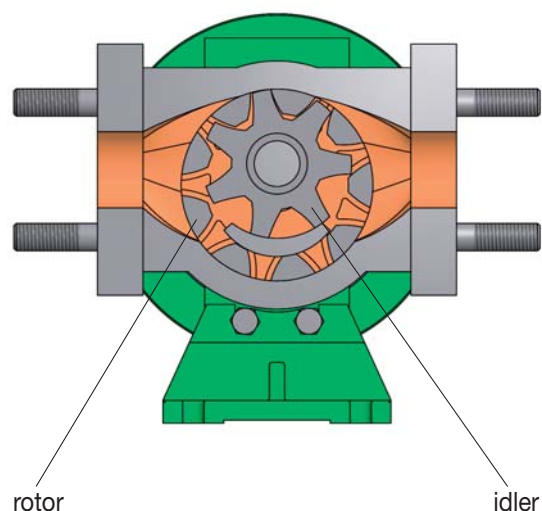

## Magnetic coupling

The single elements of the multipolar magnetic coupling are manufactured of permanent magnet material "Cobalt Samarium" with unlimited life-time. The magnets in the driven rotor are completely encapsulated, not in contact with liquid. Power is transmitted to the hermetically sealed liquid end by a bank of external magnets. Inner and outer magnet rings are locked together by magnetic forces and work as a synchronous coupling. The inner magnet ring transmits the required torque direct to the rotor. Overload of the magnetic coupling and slipping will not cause demagnetization if temperature monitoring is available. Should a subsequent increase of motor power be required, the nominal power of coupling can be increased with additional magnets.

## Containment shell

The containment shell is designed as a pressurized vessel to separate the pumpage from the atmosphere.

The containment shell is not used as an additional bearing holder. No dynamic stress occurs.

The containment shell is bolted to the bearing housing in a manner that allows removal of the bearing bracket (GML-pumps) respectively of the drive motor (GMB-pumps) together with the drive rotor without draining the pump.

## Containment shell protection

The clearances between drive rotor and motor support lantern respectively between bearing bracket and containment shell are arranged such that rubbing of the magnets on the containment shell will be avoided, even in the case of worn out ball bearings.

## Internal clearances

The internal clearance between rotor and containment shell is appr. 1,0 mm.

## Internal circulation

When pump is in operation it generates eddy currents which heat up the containment shell and the pumpage in the magnet area. This heat is dissipated by internal circulation.

GML-Design

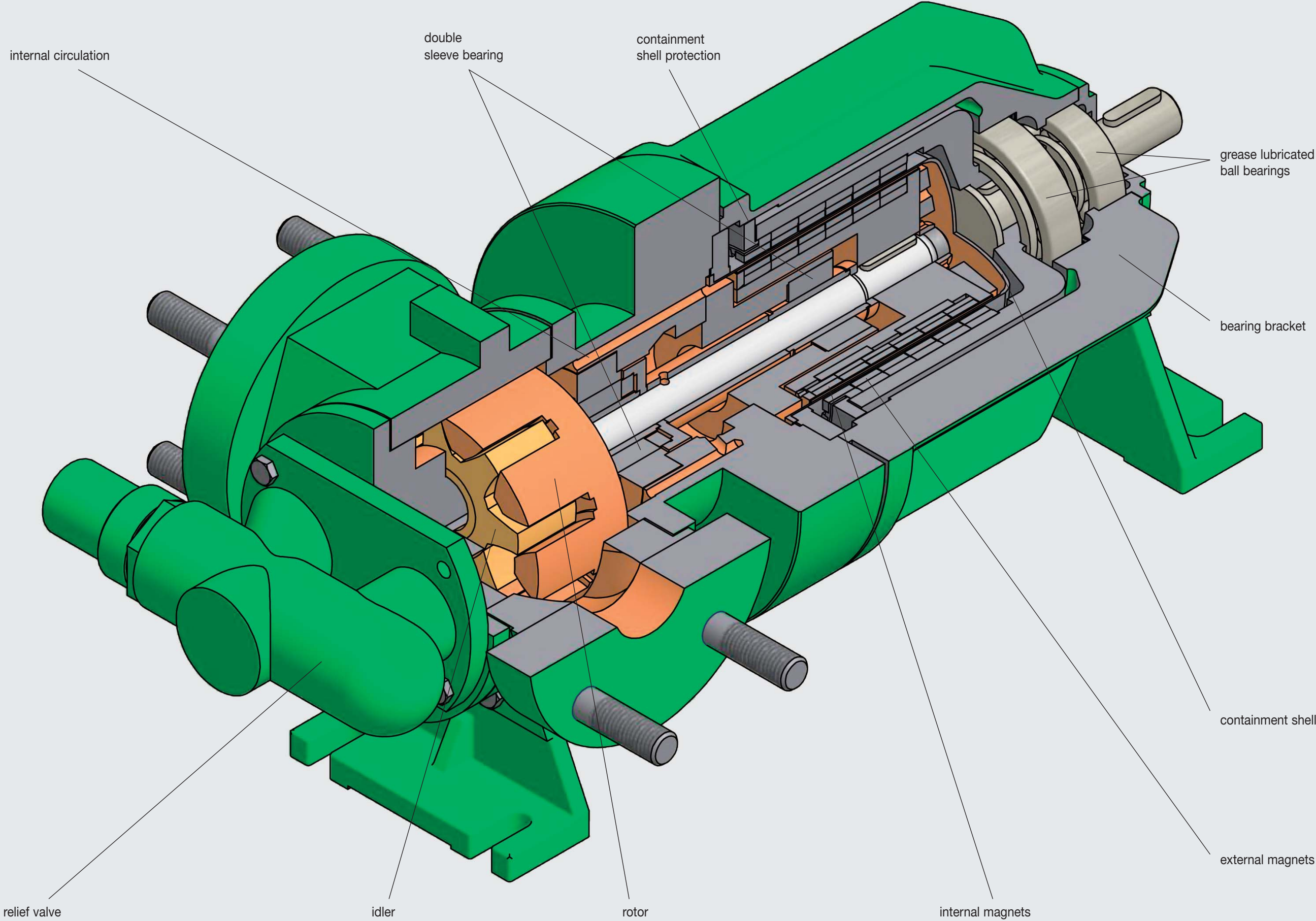



### Double sleeve bearings

The pump shaft is carried by wetted sleeve bearings. Standard material is pure Silicon Carbide with diamond layer, providing limited dry-run capability. SiC is highly resistant to corrosion and wear and can be used for all kind of liquids, also for solid containing products. The SiC-components are shrinkfitted and therefore protected against shock and thermal stress. Both sleeve bearings are bolted in one common bearing housing to grant a correct alignment.

### Outer ball bearings

The drive shaft of the GML-pumps is carried in generously dimensioned antifriction bearings, grease filled for lifetime and protected against the atmosphere by a lip seal.

The drive rotor of GMB-pumps is mounted on the motor shaft. That means, additional bearings, elastic coupling and coupling alignment are not required.

### Hazardous area

Together with the required Ex-drive motors, the GML/GMB-pumps can be applied in hazardous area Group II, Category 2. The pumps meet the basic safety and health requirements of Explosion-proof Directive 94/9 EC and are suitable for plants with increased safety requirement.

For close coupled pumps (GMB) the containment shell temperature is limited when using ex-motors. The values are available on request.

### Monitoring

Connection for temperature detection element for containment shell surface temperature is available as standard. Dry running protection and monitoring of ball bearings and containment shell temperature with the patented "mag-safe" system is highly recommended.

## Specifications, materials and size

### Carbon Steel

Model	Max. rpm	Nominal flow rate
GM 030	1800	5,7 m <sup>3</sup> /h @ 1450 rpm; 30 US gpm @ 1750 rpm
GM 080	1500	10,9 m <sup>3</sup> /h @ 920 rpm; 60 US gpm @ 1150 rpm
GM 130	1000	27,0 m <sup>3</sup> /h @ 920 rpm; 100 US gpm @ 780 rpm
GM 210	800	32,0 m <sup>3</sup> /h @ 520 rpm; 140 US gpm @ 520 rpm

### Stainless Steel

Model	Max. rpm	Nominal flow rate
GM 030	1200	3,7 m <sup>3</sup> /h @ 920 rpm; 20 US gpm @ 1150 rpm
GM 080	1000	9,1 m <sup>3</sup> /h @ 780 rpm; 40 US gpm @ 780 rpm
GM 130	640	14,8 m <sup>3</sup> /h @ 520 rpm; 65 US gpm @ 520 rpm
GM 210	520	25,0 m <sup>3</sup> /h @ 420 rpm; 110 US gpm @ 420 rpm

Issue 12.14

Technical changes reserved.  
Printed in the Federal Republic of Germany, 100-12.14 S&W



DICKOW PUMPEN GmbH & Co.KG  
P.O. Box 1254  
84465 Waldkraiburg - Germany  
Phone ++ 49 86 38 6 02 0  
Fax ++ 49 86 38 6 02 200 + 6 02 201  
info@dickow.de / export@dickow.de  
www.dickow.de

